

T-7581

3/16" PUNCH/FLANGE



OILING INSTRUCTIONS:
OIL AFTER EACH USE
WITH A FEW DROPS OF
AIRTOOL OIL THROUGH
THE AIR INLET. RUN FOR
1 SECOND TO COAT ALL
INTERNAL PARTS

MAINTAIN FLUID LEVEL (30
WT NON DETERGENT OIL)
THROUGH PLUG #6

THIS TOOL IS AN AIR OVER
HYDRALIC PUNCH/FLANGE.

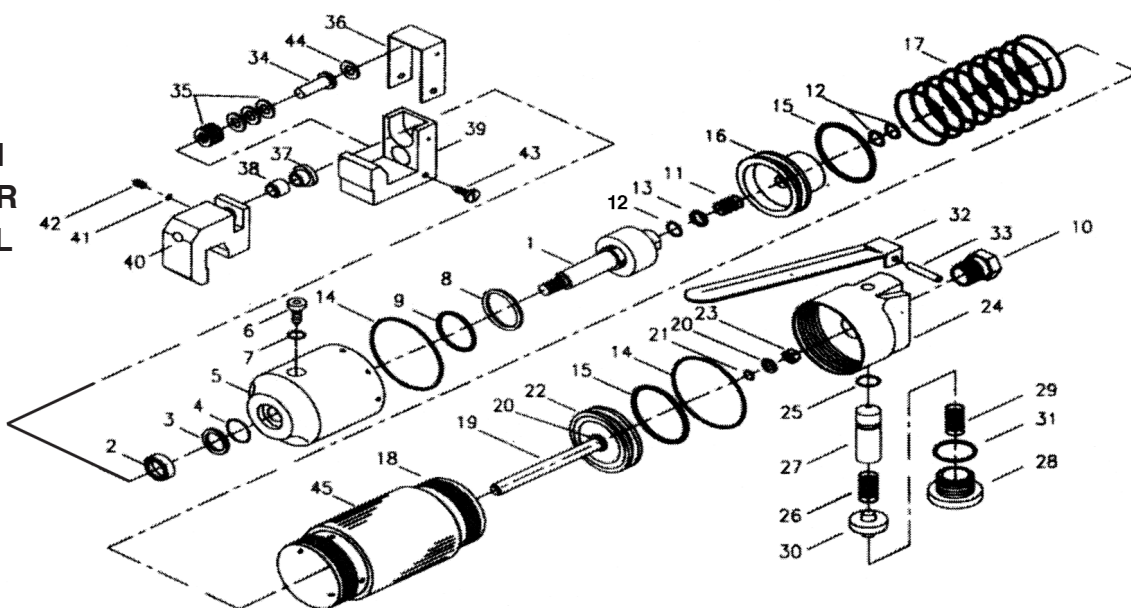

USE 90 PSI MAXIMUM

REF #	PART #	DESCRIPTION	QTY	REF #	PART #	DESCRIPTION	QTY
1	758101N	PISTON	1	24	758124N	AIR VALVE BODY	1
2	758102N	PACKING	1	25	758125N	O-RING	1
3	758103N	BACK-UP RING	1	26	758126N	SPRING	1
4	758104N	O-RING	1	27	758127N	AIR VALVE	1
5	758105N	CYLINDER	1	28	758128N	PLUG	1
6	758106N	OIL PLUG	1	29	758129N	SPRING	1
7	758107N	O-RING	1	30	758130N	VALVE COVER	1
8	758108N	BACK-UP RING	1	31	758131N	O-RING	1
9	758109N	O-RING	1	32	758132N	LEVER	1
10	758110N	AIR INLET	1	33	758133N	PIN	1
11	758111N	SPRING	1	34	758134N	PUNCH	1
12	758112N	O-RING	3	35	758135N	SPRING WASHER	12
13	758113N	BACK-UP RING	1	36	758136N	COVER	1
14	758114N	O-RING	2	37	758137N	GUIDE SLEEVE	1
15	758115N	O-RING	2	38	758138N	PUNCHING DIE	1
16	758116N	PISTON	1	39	758139N	ANVIL BED	1
17	758117N	SPRING	1	40	758140N	PUNCHIND DIE BED	1
18	758118N	CYLINDER	1	41	758141N	PACKING	1
19	758119N	PISTON ROD	1	42	758142N	SCREW	1
20	758120N	WASHER	2	43	758143N	SCREW	2
21	758121N	O-RING	1	44	758144N	WASHER	1
22	758122N	PISTON	1	45	758145N	PLASTIC COVER	1
23	758123N	LOCK NUT	1				